

**Township of Matilda**

**ENGINEER'S REPORT  
ON THE  
WESTERVELT DRAIN**

**February, 1997**

**totten sims hubicki associates  
engineers architects planners**



**ENGINEER'S REPORT  
WESTERVELT DRAIN**

**TABLE OF CONTENTS**

1.	INTRODUCTION AND BACKGROUND INFORMATION .....	1
2.	AREA REQUIRING DRAINAGE .....	1
3.	PLAN .....	1
4.	PROFILE .....	2
5.	DRAIN & WATERSHED CONDITIONS .....	2
6.	WORK RECOMMENDED .....	2
7.	FARM CROSSINGS .....	3
8.	COUNTY ROAD CROSSING .....	4
9.	ENVIRONMENTAL PROVISIONS .....	4
10.	ALLOWANCE FOR DAMAGES .....	4
11.	ALLOWANCE FOR LAND TAKEN .....	5
12.	LATERAL DRAINS .....	5
13.	DISPOSAL OF MATERIAL .....	5
14.	BELL CANADA .....	5
15.	ASSESSMENT .....	6
16.	FUTURE MAINTENANCE .....	6
17.	WORKING SPACE .....	6
18.	SUBSEQUENT PROCEEDINGS .....	6
19.	COST ESTIMATE .....	7
	Schedule A .....	9
	Schedule B .....	10
	Schedule C .....	11
	Specific Specification .....	12



**ENGINEER'S REPORT  
WESTERVELT MUNICIPAL DRAIN**

1

To the Reeve and Members of Council  
Township of Matilda

Totten Sims Hubicki Associates is pleased to submit our report on the Westervelt Municipal Drain in accordance with instructions received from Council dated December 13, 1996. This Engineering Report is being submitted for your consideration under Section 4 of the Drainage Act, 1990.

**1. INTRODUCTION AND BACKGROUND INFORMATION**

The Westervelt Drain was constructed under a report prepared by L. P. Stidwill, P.Eng., OLS, in 1968. The municipal drain was originally designed to accommodate surface drainage. This report has been prepared to deepen the municipal drain for the purpose of tile drainage of agricultural land in Concession 5. Relocations are also being proposed at the request of land owners.

The drain commences in the centre of Lot 14, Concession 5, approximately 430 metres south of a forced road through the Concession. It proceeds in a westerly and south-westerly direction outletting into the Thompson Errington Drain in the east limit of 17, Concession 4 some 330 metres south of County Road 18.

**2. AREA REQUIRING DRAINAGE**

The area requiring drainage involves the main drain between distances 935 and 1,766 within the south half of Lots 15 and 16, Concession 5. The area requiring drainage is bounded by County Road 18 to the south and Bell Road to the west.

**3. PLAN**

A plan has been prepared to show the boundary limits of the watershed. The general course of the drain is shown on the plan together with distances and a station reference. The names of property owners within the watershed have been shown within their respective properties.

Station references are provided on the plan. Stations are shown to illustrate drain alignment changes from the 1968 drainage scheme.

The plan shows the general course and alignment of the municipal drain including proposed watercourse relocations. Property owners are asked to review the plan and acquaint themselves with the works as being proposed. Should land owners have any questions concerning the proposed drainage work, these interests will be discussed at the report consideration meeting.



**4. PROFILE**

A survey has been performed on the drain. Survey results have been plotted on the attached profile. The profile illustrates the ditch bottom, average ground levels and the proposed drain grade-line. Typical ditch cross-sections are also provided on the profile.

A combined reference to the plan and profile shows the amount of deepening work recommended over any particular portion of the drain. It is intended that the accompanying plan, profile and specifications form a part of this report and that they together govern the performance of the work.

**5. DRAIN & WATERSHED CONDITIONS**

The Westervelt drain was originally designed for surface water drainage. The existing drain has an average depth of 0.9 metres (3 feet). Property owners have indicated they would like to see the drain deepened to accommodate tile drainage in the south parts of Lots 15 and 16, Concession 5.

Natural drainage characteristics of the soil are poor. The surrounding table land was wet with surface water ponding observed. These conditions are due in part to the restricted outlet afforded by the watercourse and natural soil drainage characteristics.

The topography of the Westervelt drain is level to slightly undulating. The predominant soil type is a loam of the North Gower series with some medium textured till of the Matilda series.

**6. WORK RECOMMENDED**

The North Gower soil has a silty clay matrix which has a moderate tendency to erode when the natural vegetation cover is removed. As such it is recommended that drain side slopes be constructed at 2:1 (horizontal to vertical). After construction ditch banks should be provided with a grass protective cover.

The design for the drain is the 5 year return period event during the May to October agricultural season.

To minimize soil erosion in the watercourse, the following erosion control measures have been incorporated into the open channel design:

- Re-vegetation of the drain banks following construction;
- Installation of rip-rap bank protection at sharp corners and/other erosion susceptible sites;
- Construction of stable ditch banks; and



- Installation of a temporary sediment filter during the construction period at the drain outlet.

Drain relocations alternatives have been discussed and reviewed with the property owners at the on-site meeting. The drain is being realigned between stations 14+75 and 35+92 and from 36+50 to 51+76. Abandoned sections of the watercourse between these locations will remain open where required to accommodate existing drainage. Sections to remain open include 140 metres west of station 14+73 and 80 metres north of station 51+55, along the Bell Road.

The drain depth will be lowered approximately 0.6 metres starting at distance 935 to 2,106. The drain depth between distance 449 and 935 will be sufficient to accommodate surface drainage.

**7. FARM CROSSINGS**

The installation of farm crossings are being recommended for incorporation into the drainage scheme. New culvert locations and descriptions are detailed in the following table.

**Farm Crossing Locations**

<b>Location</b>	<b>Owner</b>	<b>Recommendation</b>
Distance 1,000 m South West Part Lot 15, Concession 5	S. James & Marilyn Adams	900 mm diameter culvert is to be provided for farm access. The recommended pipe length is 8.0 metres
Distance 1,590 m East 1/2 Lot 16, Concession 5	R. Gilmour	1000 mm diameter culvert is to be provided for farm access from County Road No. 18.

Details on private access culverts are provided in Schedule "C" and Specific Specifications at the end of the report.

Before the installation of any farm crossing, the contractor will be responsible to ascertain from the land owner the precise desired culvert location. The farm crossing inlet and outlet are to be rip-rapped upon installation.

After construction these farm crossings shall be maintained in the future by the Municipality. The cost of future maintenance works on crossings is to be levied directly against the land owner on whose property the culvert is located. In the event the culvert is to be replaced in the future, the cost to install a new culvert will be distributed 50% against the scheme (upstream land owners) and 50% against the property owner.



This private access culvert maintenance provision shall apply in spite of the wording of the clause on "Future Maintenance" enclosed herein.

**8. COUNTY ROAD CROSSING**

The Westervelt Drain crosses County Road 18 at station 51+76 (South west corner of Lot 16, Concession 5). A 900 mm diameter culvert steel pipe is located under the road in this location. The 1968 engineering report found that a 900 mm diameter culvert was undersized. The recommended culvert size in this location is a 1400 mm diameter CSP.

In accordance with the Drainage Act the Road Authority has been assessed the increased cost to the drainage scheme caused by the existence of the Road. In this case, the cost of the road culvert will be levied against the United Counties of Stormont, Dundas and Glengarry. In accordance with Section 69 of the Drainage Act the Counties may elect to undertake the required road bridge work with their own forces.

All work on this crossing shall be performed in accordance with the Specific Specifications. Adherence to the road signing requirements of the Manual of Uniform Traffic Control Devices - Division 5 - Temporary Conditions is required of the contractor. Measures to be employed by the contractor must be communicated to and approved by the County Engineer, in writing, prior to commencing the work. Furthermore, the contractor must maintain traffic along the County Road at all times assisted by flaggers.

Should the Counties elect to undertake culvert work with their own forces, they will be credited in the amount of \$11,000 in Schedule A, under the heading Improvement for Benefit.

**9. ENVIRONMENTAL PROVISIONS**

In order to minimize potential adverse effects of soil erosion in the water course, the following measures are to be incorporated into any future maintenance work on the Municipal Drain:

- Temporary sediment barriers should be installed downstream of any maintenance through non-rock sections of the drain. The sediment barriers should be maintained until the disturbed ditch bottom has stabilized.
- Ditch banks which may be disturbed during maintenance work should be revegetated following construction by an application of seeding.

A recommended sod forming seed mixture is detailed in the seeding specification attach to this report.

**10. ALLOWANCE FOR DAMAGES**

Excavation and spreading of earth material from the drain over the adjoining farm land will cause a certain amount of crop damage. Also the collection of small debris from the



spreading area and possible minor fence repairs may cause extra expense for owners. It is expected land owners may be required to pick up some small stones within the spoil spread area.

The amount of the damage allowance is shown in Schedule "B".

**11. ALLOWANCE FOR LAND TAKEN**

An allowance for land taken as required to undertake the work recommended in this report is not required and as such no allowance has been made.

**12. LATERAL DRAINS**

There are no lateral drains being constructed under this report.

**13. DISPOSAL OF MATERIAL**

Excavated rock material removed from the drain shall be disposed of by hauling the rock material to a designated disposal site. Excavated hardpan material may not be spread or piled on the land adjoining the drain. Mr. James Adams has indicated hardpan and/or rock material may be stock piled at a location to be designated in the South West part of Lot 15, Concession 5. The contractor will be responsible for obtaining a release form from the owner stating his approval with the final condition of the disposal area.

Excavated earth material removed from the drain shall be spread over the adjoining land of the owners identified in the specific specifications. The depth of spreading shall not exceed 15 centimetres. Should land owners request the spreading of earth material different than shown in the specific specifications, then the land owner's preference will take precedence provided the spreading location is within the land owner's property and does not entail additional expenditure such as tree clearing or trucking. In such cases the contractor will be responsible to obtain a release form from the owner stating his preference.

For the purpose of future maintenance work these spreading provisions will apply.

**14. BELL CANADA**

It is the contractor's responsibility to ascertain the location of any buried cables or plant within the course of the drainage work. The contractor is to contact Bell Canada upon awarding of the contract for the location of any utility. The contractor is further advised the Bell Canada cables are located within the road right-of-ways.

Any costs associated with lowering buried Bell cables will be the complete responsibility of Bell Canada and are to be levied directly against Bell Canada in accordance with Section 26 of the Drainage Act.



The contractor is cautioned to exercise extreme care when digging around Bell cables. The contractor will be fully responsible for any and all damages to buried cables or utilities if caused by negligence on their part or that of any employees.

**15. ASSESSMENT**

The work to be performed under this report constitutes improvements to the Westervelt Drain and contains provisions for the construction and maintenance of the drain. All costs associated with work on the drain, as shown in the cost estimate, are to be distributed to upstream properties in accordance with Schedule "A" (Schedule of Assessment). After completion of the drainage work, actual final construction costs will be used to levy costs against the owners in accordance with this schedule of assessment.

All assessments have been shown under the headings of outlet liability and benefit. Benefit assessments has been segregated under two headings for the purpose of designating a future maintenance assessment schedule.

**16. FUTURE MAINTENANCE**

Future maintenance of the Westervelt drain will be the responsibility of the Township of Matilda. The cost of future maintenance work on the main drain is to be levied against the upstream lands and roads as shown in Schedule "A" under the heading of outlet liability and benefit. Assessments under the heading Improvement for benefit are not to be used to distribute costs for future maintenance.

Future maintenance of the drain is to be assessed against all the upstream lands and roads that drain directly into the municipal drain in accordance with the schedule of assessment under the heading outlet liability and benefit.

**17. WORKING SPACE**

The working space as required for the purpose of this drainage works, in accordance with Section 63 of the Drainage Act, shall be 15 metres as measured from each ditch side. This working space shall also include access to the drain for the purpose of hauling away rock and/or hardpan excavation material.

This working space shall also apply to future maintenance projects.

**18. SUBSEQUENT PROCEEDINGS**

Property owners are requested to review this report and familiarize themselves with the drainage works being proposed and related costs. A meeting will be convened by the Township to consider this report followed at a later date by a Court of Revision.



**ENGINEER'S REPORT  
WESTERVELT MUNICIPAL DRAIN**

**19. COST ESTIMATE**

A cost estimate of cost for the Westervelt Drain has been prepared as shown in the following table.

**Estimate of Cost**

<b>ITEM</b>	<b>QUANTITY</b>	<b>UNIT</b>	<b>AMOUNT</b>
Earth Excavation and Spreading	4,199	m <sup>3</sup>	\$12,600
Hardpan Excavation and Disposal	1,222	m <sup>3</sup>	9,700
Rock Excavation and Disposal	4	m <sup>3</sup>	400
Sediment Barrier	1	LS	500
Farm Crossings			2,400
County Road Culvert			11,000
Rip-Rap	15.2	m <sup>3</sup>	600
Gabion Erosion Protection	1	LS	1,060
Seeding	10,508	m <sup>2</sup>	3,150
Close Cut Clearing	1.06	Ha	1,060
Allowance for Damages			4,030
Engineering			6,000
Expenses (printing, etc.)			500
Inspection			3,000
Contingencies (Interest)			3,000
<b>Total Estimated Cost</b>			<b>\$59,000</b>

The total estimated cost of \$ 59,000 has been apportioned as follows:

Privately Owned Agricultural	\$ 42,562.27
Municipal Lands	<u>\$ 16,437.73</u>
<b>Total</b>	<b>\$ 59,000.00</b>



**ENGINEER'S REPORT  
WESTERVELT MUNICIPAL DRAIN**

We trust that this report will meet with Council's approval,

Respectfully submitted,

**totten sims hubicki associates**

J. D. Stidwill, P.Eng.

Kanata, Ontario, February 7, 1997





**Schedule A  
Schedule of Assessment  
Westervelt Municipal Drain**

Name of Owner	Concession	Lot or Part	Assessment Number	Area (Ha)	Outlet Liability	Benefit	Improvement Benefit
J. & G. Westervelt	5	E. 1/2 14	007-04800	10.7	996.62		
J. & G. Westervelt	5	N. Pt. 14 & 15	007-05400	25.2	4,800.90	975.55	
Delmar & James Adams S. James & Marilyn Adams	5	S. Pt. 14 & 15	007-05600	16.4	1,675.02	2,420.18	
Delmar Adams	5	S. W. Pt. 15	007-06000	7.3	1,215.15	3,577.83	2,400.00
Delmar Adams	5	Pt. 15 & 16	007-06400	26.8	3,802.10	6,401.04	2,814.00
John & Maxine Bell	5	Pt. 1 R.P. 221	07-06200	0.58	85.40		
R. Gilmour	5	S. W. Pt. 16	007-07200	10	745.05	3,651.68	3,834.00
Mahlon & Betty Casselman	5	RP-1070	07-07300	0.94	142.56		
Betty Casselman	5	E. Pt. 17	07-06800	4.9	768.47		
Betty Casselman S. James & Marilyn Adams	5	Pt.1 RP-524	07-06600	0.18	26.45		
Gordon R. & Sandra Strader	5	Pt.1 RP-2192	007-08010	1.8	272.87		
James Adams	5	Pt. 17	07-08000	0.5	74.61		
Mahlon & Betty Casselman	5	S.W. Pt. 17	07-08400	0.5	73.07		
Delmar Adams	4	N.E.Pt. 16	06-46200	0.4	27.77		
Mahlon & Betty Casselman	4	Pt. 16	06-47800	1.4	108.17		
Mahlon & Betty Casselman	4	N.W.Pt. 16	06-47000	2.7	117.96	364.19	
Mahlon & Betty Casselman	4	N.E.Pt. 17	06-48800	2.1	157.44	364.19	670.00
United Counties of Stormont, Dundas & Glengarry		County Road 18		1.5	399.22	1,529.15	13,800.00
Matilda Township		Bell Road		0.9	478.07	231.29	

**Total                    114.8    15,966.90    19,515.10    23,518.00**



**Schedule B  
Allowance for Damages  
Westervelt Municipal Drain**

<b>Name of Owner</b>	<b>Concession</b>	<b>Assessment Roll Number</b>	<b>Property Description</b>	<b>Allowance</b>
S. James & Marilyn Adams	5	007-06000	S. W. Pt. 15	730
Delmar Adams	5	007-06400	Pt. 15 & 16	1,070
R. Gilmour	5	007-07200	S. W. Pt. 16	1,560
Mahlon & Betty Casselman	4	06-48800	N. E. Pt. 17	670



**Schedule C  
Culverts**

<b>Owner</b>	<b>Property Description</b>	<b>Culvert Diameter (mm)</b>	<b>Culvert Length (m)</b>	<b>Thickness (mm)</b>	<b>Corrugation (mm x mm)</b>
S. James & Marilyn Adams	S.W.Pt. 15	900	8	1.6	68 x 13
R. Gilmour	S.W.Pt. 16	1000	8	1.6	68 x 13
Counties of SD&G	County Road 18	1400	20	1.6	76 x 25



**Specific Specification  
Westervelt Drain**

The Municipal Drain General Specifications are to be supplemented by these specific specifications.

**1. Ditch Dimensions**

A description of the drain work dimensions for open cut ditch construction are as follows:

Bottom Width: 0.9 m  
Side Slopes: 2:1 (horizontal to vertical)

**2. Excavation Location and Earth Material Spread Direction**

The location of the municipal drain as illustrated on the accompanying plan is supplemented by the follow information:

<b>Distance Interval (m)</b>	<b>Excavation Location</b>	<b>Spread Direction</b>
449 to 935	Within West 1/2 of Lot 15	West (surplus earth spoil material after infilling existing ditch as described in article 3).
935 to 1291.22	As illustrated on the Plan	South (surplus earth spoil material after infilling existing ditch as described in article 3).
1291.22 to 1584	Within West 1/2 of Lot 16	West (surplus earth spoil material after infilling existing ditch as described in article 3).
1584 to 1766.7	Within West 1/2 of Lot 16 (outside road allowance)	North (surplus earth spoil material after infilling existing ditch as described in article 3).
1783.5 to 2106.6	Follow existing ditch location	West



### 3. Ditch Infill Locations

Existing ditch locations to be filled in and levelled with earth excavation material are as follows:

#### Description

Existing ditch between stations 19+73 and 37+52 (W1/2 15 & E1/2 16, Concession 5). The ditch section between 14+73 and 19+73 is to remain open;

Existing ditch between stations 38+92 and 49+06 (W1/2 16, Concession 5). The ditch section between 49+06 and 51+76 is to remain open.

### 4. Rip-Rap and Gabion

Stone rip-rap and gabion are required for erosion protection at the following locations:

Location	Description
935	<i>Gabion Drop Structure</i> 5m x 3m x 0.3m (l x w x t) gabion plus 6m x 3m x 0.3m plus 1.8 m <sup>3</sup> rip-rap in ditch bottom drop structure. Rip-rap volume is 11.7 m <sup>3</sup> ; filter fabric area is 50 m <sup>2</sup> .
935	<i>Corner Rip-rap Protection</i> Rip-rap protection for outside ditch bend. Dimensions are 10 m x 1.2m x 0.3m (Length x height x thickness). Rip-rap volume is 3.6 m <sup>3</sup> , filter fabric area is 20 m <sup>2</sup> .
1,291	<i>Corner Rip-rap Protection</i> Same dimensions as distance 935.
1,584	<i>Corner Rip-rap Protection</i> Same dimensions as distance 935.
7,166.7	<i>Opposite Ditch Bank Protection</i> Rip-rap for opposite ditch bank protection. Dimensions are 6 m x 1.2m x 0.3m (Length x height x thickness). Rip-rap volume is 2.2 m <sup>3</sup> , filter fabric area is 12 m <sup>2</sup> .
2,106.6	<i>Opposite Ditch Bank Protection</i> Rip-rap for opposite ditch bank protection. Dimensions are 6 m x 1.2m x 0.3m (Length x height x thickness). Rip-rap volume is 2.2 m <sup>3</sup> , filter fabric area is 12 m <sup>2</sup> .



Filter fabric material is to have an equivalent opening size of No. 120 (ESO) U.S. sieve and have suitable burst strength for placement under stone rip-rap material. The geotextile fabric material is to be non-woven.

Gabion mats shall be supplied by Maccaferri Gabion or other manufactures, subject to approval of material specifications by the engineer. Blasted stone or field stones ranging in size between 100 mm and 200 mm in diameter shall be used as rock fill for gabion mats. All mats are to be installed as per the manufacture's recommendations.

Filter fabric areas are based on theoretical dimensions. The contractor is to include any allowance for material wastage or overlap as may be required in the performance of this item. The contractor is advised that backfill of erosion protection material over the filter fabric is not to be allowed until the engineer's representative has inspected and approved the placement of the filter fabric.

#### **5. Seeding**

Excavated ditch banks and bottom are to be seeded as soon as possible after ditch excavation work, preferably at the end of each day after final shaping to ensure best conditions for seed germination. The seed mixture for seeding is to be as follows:

Mixture	% by weight
Creeping Red Fescue	50
Kentucky Blue Grass	15
Trefoil	5
Companion Crop (oats in spring, wheat in fall)	25
White Dutch Clover	5

Sowing rate: 100 kg per hectare

A 10-10-10 fertilizer is to be applied to the ditch banks before seeding at a rate of 120 kg/ha.

Should the seeding not successfully catch after the first seeding due to the contractor not following the recommended seeding guidelines (attached), then the contractor will be responsible for re-seeding the drain at their own expense.

#### **6. Fencing**

Any existing fencing which is disturbed or removed by the contractor during the execution of the work must be restored to its original or better condition by the contractor as part of the contract. No extra payment will be allowed for fence restoration work.



**7. County Road Culvert**

The existing County road culvert is to be replaced with a new culvert steel pipe. The culvert is to be installed 0.1 metre below the drain design grade line. All work is to be performed in accordance with the County Road construction specifications (attached) and to the satisfaction of the County and drainage engineer.

At least one lane of traffic must be provided during the pipe installation at all times. Proper signing and flagging must be provided during the installation in accordance with the Manual of Uniform Traffic Control Devices - Division 5 - Temporary Conditions.

Quantity Estimates and related specifications which govern the performance of the work are identified as follows:

<b>ITEM</b>	<b>SPECIFICATIONS</b>	<b>QUANTITY</b>
Bedding	OPSD 802.01 - Type 2 150 mm Granular A W=2350 mm Compaction to 95% Std. Proctor Density	
Backfill	OPSD 803.03 - Case 1 Compaction to 95% Std. Proctor Density	
Road Subbase	450 mm granular B crushed stone Compaction to 100 % Std. Proctor Density	
Road Base	150 mm granular A crushed stone Compaction to 100 % Std. Proctor Density	
Road base and subbase:		
Granular A		21 tonnes
Granular B		64 tonnes
Culvert bedding and cover backfill:		
Granular A		140 tonnes
Asphalt	80 mm HL8 applied in two lifts, 40 mm HL4 surface lift 96 % Marshall density	11 tonnes

Granular material in the road based may be re-used if not contaminated with other sub-soil material, for culvert backfill material. The asphalt road surface is to be saw cut in an inverted fishtail pattern in accordance with OPSD 507.01. The contractor is to be responsible for the cost of all soil testing under this item.



The contractor is to make their own estimate of the quantities of material required for this item and shall not rely solely on the Engineer's estimate in preparing the bid tender price.

**8. Private Access Culvert Installations**

All private access culverts are to be new CSP material. The culverts are to be installed 0.1 metres below the ditch design grade. The contractor is to contact the land owner to determine the exact culvert installation location. Upon installation the culvert is to be backfilled with stable material and rip-rapped with blasted quarry stone underlain with a suitable geo-textile non woven filter fabric (ESO 120). All stones are to be placed and keyed in as shown on the standard drawing entitled "Rip-Rap at Culverts".

**9. Clearing (Close Cut)**

Close cut clearing of all trees and brush on or near the ditch bank for spreading purposes will be required. All cleared brush and branches are to be neatly piled. Tree trunks greater than 100 mm diameter are to be cut in 1.2 metre lengths, or longer if desired by the owner, and piled in a location along the drain convenient for the owner to retrieve. The tree clearing width is to be measured 15.0 metres back from the top of the final excavated ditch bank. All cleared trees remain the property of the land owner.

**10. Construction Satisfaction Statement**

The contractor is required to obtain a construction satisfaction statement from the property owner or their agents, as per the enclosed attached statement. The statement when signed is to be forwarded to the Engineer upon completion of the work. The cost of obtaining this form from the property owner is the responsibility of the contractor which cost is to be included in the unit cost for earth excavation.

1  
2  
3  
4  
5  
6  
7  
8  
9  
10  
11  
12  
13  
14  
15  
16  
17  
18  
19  
20  
21  
22  
23  
24  
25  
26  
27  
28  
29  
30  
31  
32  
33  
34  
35  
36  
37  
38  
39  
40  
41  
42  
43  
44  
45  
46  
47  
48  
49  
50  
51  
52  
53  
54  
55  
56  
57  
58  
59  
60  
61  
62  
63  
64  
65  
66  
67  
68  
69  
70  
71  
72  
73  
74  
75  
76  
77  
78  
79  
80  
81  
82  
83  
84  
85  
86  
87  
88  
89  
90  
91  
92  
93  
94  
95  
96  
97  
98  
99  
100

GENERAL SPECIFICATIONS

INDEX

SECTION 2.0

- 2.1 Scope
- 2.2 Description of Work
- 2.3 Classification of Excavated Material
- 2.4 Reclassification
- 2.5 Roads to be kept open
- 2.6 Relief Ditches
- 2.7 Damages
- 2.8 Clearing and Grubbing
- 2.9 Close cut Clearing
- 2.10 Fencing
- 2.11 Farm Crossings
- 2.12 Rip-Rap
- 2.13 Lateral Drain Connections
- 2.14 Excavation
- 2.15 Basis of Payment
- 2.16 Measurement for Payment
- 2.17 Disposal of Material
- 2.18 Road Culvert
- 2.19 Grades
- 2.20 Date for Completion
- 2.21 Payments
- 2.22 Right to Reject Tenders
- 2.23 Workmen's Compensation

2.24 Right to Increase or Decrease the Work

2.25 Sub-Letting

2.26 Deposit to Accompany Tenders

2.27 Meaning of Terms

2.28 Rock Excavation and Blasting

2.29 Removal of Obstructions

## Section 2.0

### GENERAL SPECIFICATIONS

#### 2.1 Scope

These specifications are drawn up to cover the work as outlined in the Engineer's Report on the Drain, the said report forming part of these specifications.

Where there is any doubt as to the meaning or intention of the report and specifications as a whole it shall be the Contractor's duty to obtain a ruling from the Engineer before proceeding with the work.

#### 2.2 Description of Work

The work to be done shall consist of making the necessary excavation to the grade and dimensions as shown on the accompanying profile and more particularly described in these specifications, also, the cutting of any brush that may be necessary, grubbing of roots and the removal and disposal of all excavated material to points hereinafter mentioned.

#### 2.3 Classification of Excavated Material

All excavated material shall be classified under the following headings: "Earth", "Hardpan", and "Rock", for the purpose of payment.

"Rock Excavation" means:

- a) material excavated from solid masses of igneous, sedimentary or metamorphic rock, which prior to removal was integral with the parent mass and
- b) boulders and rock fragments encountered during excavation measuring in volume 0.4 metres cubed (14 cu.ft.) or more, but
- c) notwithstanding Clause a) and b), the removal of dense tills, hardpan, and any other similar materials shall not be Rock Excavation for purposes of payment.

Payment of "Rock Excavation" for boulders or fragments of rock shall be based on actual measurements only, and the Contractor shall give the Engineer the opportunity to make the required measurements.

If additional Rock is encountered, other than that shown on the profile, the Contractor shall notify the Engineer of its location prior to excavation. The Engineer may adjust the grade line or ditch location to avoid such excavation as he deems necessary.

#### "Hardpan Excavation"

Hardpan Excavation shall comprise of the excavation of very dense cemented or compacted material generally a clayey type material not easily penetrated, or glacial material. In cases of dispute, the Engineer's decision regarding classification of hardpan shall be final.

Payment as "Hardpan Excavation" shall be based on actual measurement only and the Contractor shall give the Engineer the opportunity to make the required measurement.

#### "Earth Excavation"

Earth Excavation shall comprise the excavation of all other materials of whatsoever nature that do not come under the classification of "Rock Excavation" or "Hardpan Excavation" and shall include frozen earth material and loose and shattered rock fragments.

### 2.4 Reclassification

No claim for reclassification of material will be allowed without positive evidence as to the exact location where the reclassification is necessary, and in the case of boulders, the exact size (Height, Width and Circumference measured in two directions) of each boulder encountered.

### 2.5 Roads to be Kept Open

All public and private roads shall be kept open and in a passable condition during the continuance of the work.

## 2.6 Relief Ditches

In case the Contractor may make relief ditches, he must do so and refill the same at his own expense.

## 2.7 Damages

In case of damage being done to any farm or other property along the line of work by blasting or other operations, the Contractor shall be held liable for such damage.

The Contractor shall also rebuild and leave in as good a condition as possible all fences removed in order to execute the work. When hay or other produce is growing on the lands adjacent to the proposed work, the Contractor must give the owner ten (10) days notice in writing to remove the same before he begins work on that portion, otherwise he shall be held liable for any damage caused.

## 2.8 Clearing and Grubbing

Any brush growing on the banks ( 3 feet beyond the ditch bank) or in the ditch, must be grubbed out clean or as otherwise directed by the Engineer. Small brush removed is to be piled in a neat and workmanlike manner so that it may be burned by the farmer. Large trees are not to be cut unless absolutely necessary for the execution of the work. If large trees are cut, the stumps are to be removed from the premises to a suitable dumping place away from the cultivated land, and away from the spreading area. If a suitable dumping place is not available on the property, on which the drain is located, then the stumps will be removed to the Township dump or other suitable disposal area by the Contractor as part of his contract. The Contractor is to be responsible to locate such suitable disposal sites as may be necessary, and is to assume responsibility for the use of such disposal area.

Small branches are to be cut and piled so that they may be burned by the farmers, and the trunks of large trees and branches cut into log lengths and piled clear of the drain so that they may be salvaged by the farmer. I wish to impress upon Contractor that he is to avoid cutting large trees if at all possible. Also, the necessity of carrying out grubbing in a clean and workmanlike manner. If the Contractor wishes to bulldoze out small shrubs into piles, he shall be responsible for the burning of this material.

The spreading of spoil directly on small brush without previous grubbing will only be allowed in swamp and muck land at the locations mentioned later in these specifications

Burning is to be allowed only where permitted by local and/or provincial legislation.

Payment for clearing and grubbing is to be in accordance with the Tender Form. Where Clearing and Grubbing are not included in the Tender Form, the cost of such work is to be included in the cost of Earth Work or Contingency if provided in the Form.

#### 2.9 Close Cut Clearing

Where drains pass through dense brush and forest land, close cut clearing shall be allowed if so stated in the Engineer's Report. Close cut clearing shall consist of cutting off at ground level or as close to ground level as practical. Disposal of the branches and log lengths shall be in accordance with Clause 2.8 (Clearing and Grubbing).

Payment for close cut clearing is to be in accordance with the Tender Form. Where no separate item is included in the Tender Form, the Contractor is solely responsible for determining the magnitude of such work under this item and shall include the cost of such work in the unit price of Earth Excavation or Contingency if provided in the Form.

#### 2.10 Fencing

Any and all fencing which must be removed by the Contractor during the course of this work shall be repaired or replaced as may be necessary so as to be in as good a condition as prior to work commencement. Where necessary, the Contractor will be responsible to erect temporary fencing to contain livestock.

During fence re-installation, the Contractor shall incorporate the re-usable fencing material into the fence. If the Owner supplies new material, then the Contractor shall use this new material for the re-erection of the fence.

## 2.11 Farm Crossings

Included in this contract is the supply and installation by the Contractor of a number of farm crossings as shown on the accompanying schedule.

It is the Contractor's duty to contact each owner prior to the installation of each crossing to determine its most desirable location. The old pipes remain the property of the land owners.

Only new, galvanized, corrugated steel culverts are to be used having the correct inside diameter, length and gauge as indicated in the Schedule. The quality of the pipes or substitution of other material is subject to the approval of the Engineer.

Each pipe will be laid on undisturbed soil and at the correct bottom grade. Construction of the crossings includes the backfill which will be shaped and compacted by the Contractor in a good and workmanlike manner to the satisfaction of the Engineer. The minimum cover over each pipe will be 0.3 metres regardless of the level of the surrounding field, and the minimum width of each roadway crossing the pipe will be 6.0 metres. Ground used for backfill over culverts shall not contain old wood or other debris, nor stumps. Backfill with soil containing a high percentage of muck or pure sterile sand must not be used.

Installation of farm crossings shall be in accordance with the Drawing entitled "Installation of Farm Culverts".

## 2.12 Rip-Rap

Both ends of each culvert will be rip-rapped with quarry stones hand placed, starting from the bottom of the new Drain to a level of 0.3 metres below the average field elevation. Stones will have a minimum thickness of 200mm. and will be laid flat on top of each other with an inward slope of one vertical unit per two horizontal units. All stones for rip-rap shall be supplied by the Contractor. This work is to be done in a neat and workmanlike manner to the satisfaction of the Engineer.

The Contractor is responsible for one year from the date of the final acceptance of the work for washing out of a culvert, the falling down of the rip-rap or the washing off of the cover, if due to faulty installation. This will be determined by the Engineer.

The Contractor shall contact each owner along the Drain to have the location of underground tile outlets marked out in the field.

All access culverts to farm buildings will be finished off with at least 6 cubic metres of 15mm crushed stone on gravel over at least 450mm of pitrun gravel properly compacted to avoid settling of material. If untimely settling takes place causing a dip in the laneway, the Contractor will be held responsible to repair the same up to a time limit of one year from the time of final approval by the Engineer. This also applies to rip-rap on all culverts.

### 2.13 Lateral Drain Connections

All existing lateral drain-junctions including private drain-junctions not being constructed under this contract are to be excavated back a distance of 10 metres (30 feet) measured from the centre line of the ditch to allow a uniformly sloped connection to the constructed works.

No rock or hardpan excavation shall be required for the improvement of junctions. No measurement of quantities shall be made in respect of earth excavation to construct junctions, such work being deemed to be identical to and included in the unit price bid for earth excavation under this contract.

### 2.14 Excavation

The Contractor shall excavate the channel to the design lines, grades and cross-sections shown on the Contract Drawings. The ditch bottom shall be excavated to an even grade between the stations so that no water may lie stagnant therein.

The Contractor shall not excavate outside the slopes or below the established grade unless directed by the Engineer.

Where straightening occurs, as shown on the plan and profile, The Contractor shall fill in the abandoned ditch throughout its entire length from shoulder to shoulder with the excavated material taken from the Drain. They may or may not entail transportation of the excavated material by trucks or other equipment. The cost of this work is to be included in the unit price for excavated earth quoted by the Contractor in his Tender Price.

The bottom of the ditch shall be brought to an even grade between the stations so that no water may lie stagnant therein.

Bottom widths and side slopes are as shown on the profile.

Rock cuts, should they occur, and unless indicated on the profile, shall have vertical sides and width equal to the specified bottom width of the drain at that point.

Generally, the excavation work is to commence at the lower or downstream end, and proceed upstream, unless otherwise authorized or ordered by the Engineer in writing.

The Contractor shall excavate the channel to the designed lines, grades and cross section shown on the Contract Drawings. Removal of snow and ice shall be incidental to and included in the unit price bid for earth excavation.

The Contractor shall not excavate outside the slopes or below the established grade unless directed by the Engineer. All earth cuts shall be finished to true sections in the channel, cleaned and trimmed as the channel excavation progresses.

Where rock excavation is required, all blasting shall be carried out in accordance with Section 213 of MTC Drawing 200. All rock cuts shall be excavated to the slope and grade line shown on the Drawings, with no rock projecting theoretical slopes and grades.

### 2.15 Basis of Payment

Payment for Excavated Material shall be made at the Contract unit price per cubic yard or metre cubed (as so stated in the Tender Form) for "Earth", "Hardpan", or "Rock", as the case may be, and shall be full compensation for all excavation, disposal of respective material (as per Clause 2.17), and/or clearing, grubbing or close cut clearing, fence repairs, including disposal of resulting debris and the improvement of lateral drain junctions.

### 2.16 Measurement for Payment

Measurement for payment shall be made in cubic yard or metres cubed of excavated material within the theoretical lines, slopes and grades shown on the Drawings.

### 2.17 Disposal of Material

The excavated material shall be disposed of so as to do as little damage to lands and crops as possible. In cultivated land, it shall be taken back at least 8 feet in width on which no material is to be spread. Channels shall be cut every 50 metres to prevent stagnant surface water from building up behind the spreading area. If the earth is spread along unopened road allowances, it shall be so spread that no holes remain along the roadway and so crowned that no water will remain along the roadway or lie on the roadway.

The excavated material shall be spread and levelled by means of a bulldozer, or similar equipment so that the finished work presents a neat appearance and leaves the land so that it can be easily worked by the farmer and particular location does not exceed the elevation of the adjoining land by more than 150mm in cultivated land, and 300mm in the case where spreading is done in wooded areas.

All excavated hardpan, cut stumps and excavated stones shall be disposed of by the Contractor. Hardpan or stones may be buried by the Contractor if covered by at least 0.9 metres of good soil. In the event that the Contractor buries

the hardpan or stones, a release stating that he is satisfied with the work shall be obtained from the Owner of the property. If not buried, all hardpan and stones shall be removed and disposed of by the Contractor. Stumps will have to be removed from all work land. No hardpan is to be spread on work land or land that will be in a workable state after removal of brush and/or willow slash.

During excavation of the Drain, the Contractor shall endeavour to keep earth and hardpan or rock separated as much as possible, so as to facilitate subsequent loading and removal of hardpan and rock. In the case where a dispute arises between the land owner and the Contractor on the subject of classification of material, the Engineer shall be called in and his decision will be final.

On non-tillable lands, marshlands or muskeg areas where it is difficult for normal construction equipment to operate, the earth material and/or hardpan material may be left in a flattened windrow upon approval of the Engineer. Such a windrow must be sufficiently flattened and trimmed to allow the passage of a farm tractor and maintenance equipment. To ensure that the drainage from adjacent lands is not impeded, drainage openings shall be constructed wherever required or as otherwise stipulated in the Contract Documents.

#### 2.18 Road Culverts

The Contractor is to clean out under any existing open bottom road culverts which are of sufficient size and is also to clean out any such pipe culvert which has been accepted by the Engineer as being of a satisfactory size and at proper depth.

Unless otherwise stated elsewhere in this report, any work other than the above which may be required at the site of the road culvert shall be charged against the road costs and shall be the responsibility of the Road Superintendent concerned. In order to make his equipment available for any excavation required by the lowering or replacing of a pipe culvert, not included in the scheme, the Contractor shall give the Road Superintendent concerned ten (10) days notice in writing, informing him when he will reach the site of any given culvert requiring work. Should the Road Superintendent prefer to carry out the work using his own equipment and personnel, the Contractor shall only be required to excavate to the grade up to and away from any such culvert.

## 2.19 Grades

The Engineer will provide the Contractor with bench marks and central points as required.

The Contractor shall provide qualified personnel to properly lay out and establish secondary lines and grades necessary for construction. The Contractor shall be responsible for the true and proper setting out of the works, including the installation of grade stakes, offsets, alignment markers and the provision of all instruments, equipment and labour in connection therewith.

If, at any time during the progress of the work, any error appears or arises in the position, levels, dimensions, or alignment of any part of the work, the Contractor shall at his own expense rectify such error to the satisfaction of the Engineer, unless such error is based on incorrect data supplied in writing by the Engineer. The checking of the setting out of any line or level by the Engineer shall not relieve the Contractor of his responsibility for the correctness thereof. The Contractor shall carefully protect and preserve all bench marks, stakes and points of reference used in setting out the works.

The Contractor is to furnish the Engineer with any reasonable assistance which may be required at any time in checking the work.

If stakes, survey points or bench marks have to be replaced, after having once been given, they shall be reset at the Contractor's expense.

## 2.20 Date for Completion

The whole of the work shall be completed on or before the \_\_\_\_\_ day of \_\_\_\_\_ 19\_\_\_\_, including the spreading, and when the Contractor considers that the work is completed he must notify the Engineer in writing that he requires a final inspection thereof.

The cost of inspecting the work done by the Contractor shall be paid by the Municipality. However, should it be found that the work, upon inspection by the Engineer has not been done in accordance with these specifications, the

Contractor shall then be responsible for any subsequent costs brought about by all extra work, e.g., replacing hubs, re-inspecting the work, etc., and the cost of this extra work shall be deducted from the final Progress Payment issued to the Municipality.

The Contractor shall forfeit the amount of \$100.00 per day from his contract for every day's delay in completion of the work after the date of completion unless he has been granted an extension of time by the Council of the Municipality.

#### 2.21 Payments

Cash payments will be made monthly equal to ninety percent (90%) of the value of the work done on the certificate of the Engineer, should the amount of work done within the month amount to One Thousand Dollars (\$1,000.00). The remaining ten percent will be retained until forty-five (45) days after the whole work has been accepted as finished.

#### 2.22 Right to Reject Tenders

The Municipal Council reserves the right to reject any or all tenders.

#### 2.23 Workmen's Compensation

The Contractor shall comply with the Regulations of the Workmen's Compensation Board of Ontario.

#### 2.24 Right to Increase or Decrease the Work

The Municipality reserves the right when it is deemed advisable by the Engineer to increase or decrease the amount of excavation or to deviate from the line or grade of the proposed work as shown by the Drawings, but no variation shall be made from the price per unit of measurement named in the Contract in consequence of any such change.

#### 2.25 Sub-Letting

No portion of the work is to be sub-let without the consent of the Municipal Council and the Engineer.

#### 2.26 Deposit to Accompany Tenders

A cash deposit or certified cheque on a chartered bank for the sum amounting to ten percent of the tendered price must accompany each tender. Such deposit will be returned to the unsuccessful bidders at once.

Upon acceptance of the Tender, and if required by the Municipality, the Contractor shall deposit with the Township Treasurer a performance bond equal to one hundred percent (100%) covering the total sum of the Contract. Upon receipt of this performance bond, the ten percent (10%) deposit cheque will be immediately returned to the Contractor.

The Performance Bond (if required) shall cover the work to a time limit of six (6) months after the work has been accepted by the Engineer as finished.

#### 2.27 Meaning of Terms

In the General Specifications the words "MUNICIPAL COUNCIL" shall mean the Municipal Council of the Township.

"REEVE" shall mean the Reeve of the Township.

"ENGINEER" shall mean the Engineer in charge of the work or his authorized representative.

#### 2.28 Rock Excavation and Blasting

- a) Rock shall be taken out carefully by approved methods to the line and grades shown on the Drawings. Drilling and blasting and other quarry methods shall be carefully done to avoid opening seams or shattering and splitting rock beyond or below specified line and grades.

- b) If blasting for rock excavation or demolition work is required, it shall be done only by men experienced in such work and conducted in such a manner as to be perfectly safe to workmen and to the public and to ensure the safety of nearby structures and properties.
- c) Adequate blasting mats, or other devices approved by the Engineer, shall be used to retain the rock within the excavated area and prevent flying rock. Particular care is to be taken at all times that no injury or damages are caused through the blasting operations. All exposed structures are to be protected from the blasting and all damage caused is to be replaced promptly. Where, in the opinion of the Engineer, blasting may injure adjacent structures or utilities, whether private or public, above ground or under ground, or may cause injury or damage, the Engineer shall have the authority to require the use of additional blasting mats or to limit the charge in any one blast.
- d) The Contractor shall give daily notice to all residents nearby or as may be designated by the Engineer, that blasting will be carried out that day. Immediately prior to blasting, the immediate area shall be cleared, watchmen shall be posted at all public routes leading into the area, and public entry prohibited until the blasting is safely completed.

#### 2.29 Removal of Obstructions

The Contractor is to exercise the utmost caution in the removal of any and all beaver dams and/or obstructions in the ditch, to ensure that any water built up behind such an obstruction will not be released suddenly. The release of water behind dams or obstructions shall be controlled so that no downstream flooding damage to the municipal drain and/or bridges will occur. During removal of such obstructions the Contractor should submit to the Engineer in writing the methodology for controlled release of such water, if in doubt as to the proper methodology to be employed. The Contractor will be fully responsible for any and all flood damage to surrounding land and/or the municipal drain and bridges caused by uncontrolled release of water behind an obstruction or dam in the municipal drain.



## SEEDING SPECIFICATIONS

### Mulching Material (if required under the Contract)

The material used for mulching shall normally be oat or wheat straw. Where oat or wheat straw is not available, other similar vegetative material may be used on approval by the Engineer. All mulching material shall be dry and on being processed through a conventional mulch blower, shall form an evenly distributed mat. Straw shall be supplied in bales and shall be free of weeds and all other foreign matter.

Mulch material shall be applied with an approved mulch blower, and at the time of application, the straw shall be sufficiently dry that it can be processed without stoppage through the blower.

Application shall be even over the areas designated by the Engineer. The rate of application shall be such as to result in a depth of not less than 25mm, or more than 50mm measured at the time of application.

Mulching shall follow seeding on the same day except, however, where the condition of the soil creates immediate danger of erosion, the Engineer may require mulching prior to seeding. No extra payment will be made for carrying out the work in this order.

### Preparation of Surface

Grading and topsoiling, when part of the work under the Contract, shall be completed prior to seeding.

The area to be seeded shall be scarified so as to loosen the soil to a depth of 25mm. Stones and surface litter exposed by this operation shall be removed. Scarification shall be carried out by discing, harrowing, hand raking or by other means acceptable to the Engineer. Should the Engineer require the removal of any other debris or any vegetation which would be detrimental to the desired growth, such removal will be the responsibility of the Contractor, provided however, that the Engineer directs the Contractor to perform all or any part of such work. The Contractor shall provide the Engineer with a quotation for such extra work, which quotation must be approved by the Engineer prior to undertaking the work.

Application of a suitable fertilizer as specified by the Engineer should be applied before seeding takes place.

Seeding

The distribution of nurse crop seed, grass seed and fertilizers, shall be uniform over the area designated by the Engineer.

Grass seed and fertilizers shall be thoroughly mixed with water and distributed by means of an approved hydraulic seeder.

After charging, no water or other material shall be added to the mixture in the seeder. No area shall be seeded which cannot be mulched on the same day as it is sown except in the case of seeding after straw mulching.

Weather and Seasonal Conditions.

Work under this specification shall proceed only in calm weather and on ground free of frost, snow, ice or standing water, and when, in the opinion of the Engineer, weather and seasonal conditions are suitable.

The Engineer will not permit the work to proceed when wind conditions are such that material would be carried beyond the areas designated for the work, or that the material would not be applied uniformly.

Contractor's Responsibility for the Work.

The Contractor shall be responsible for the protection of the work and shall at his own expense restore to the requirements of this specification any seeding damaged by any cause whatever, until the work shall have been accepted by the Engineer. After the Contractor has notified the Engineer, that the work or a portion thereof has been satisfactorily completed, the Contractor shall keep at the contract side until the work shall have been finally accepted, sufficient forces and equipment to carry out such touch-up work as, in the opinion of the Engineer, may be required to place the work in an acceptable condition.

## COUNTY ROAD CULVERTS

### SPECIFICATIONS - WORK ACROSS COUNTY ROADS.

In cases where work across County Roads is required, the contractor will submit a separate tender price for any work across the County Road, excepting the normal excavation of the open channel to and away from the County Road.

The separate tender price will include all the work, including the supply of material required for the lowering, or replacement, of an existing culvert, or the installation of a new road culvert.

After installation, the invert of elevation of the road culvert shall be 50mm to 300mm below stream bed elevation; as shown on the Profile which accompanies the Engineer's Report for that municipal drain.

In cases where the present structure cannot again be used, upon instruction by the County Engineer or his representative the contractor will supply and install a new pipe of the size and gauge as specified.

### REMOVAL OF OLD STRUCTURE

Prior to the installation of culverts, old discarded structures will be completely excavated and removed from the site. This includes old pipes, fragments of concrete bridges, and re-inforcing steel, also old wood, timber or other debris.

### INSTALLATION AND BACKFILL

All installation and backfill shall conform to M.T.C. Specifications and Standards. The following general points are to be considered:

1. The top 150mm will consist of 20mm crushed stone or gravel (Granular "A").
2. From 150mm to 600mm depth, pitrun gravel is to be used (Granular "B").
3. Compaction will be done to a density of 100% for granular material or 95% for native material, using a compactor or vibrator of general accepted type, as approved by the County Engineer, or supervising foreman.

4. Black top does not have to be replaced.
5. The County Engineer or foreman will be given a minimum of 10 days notice in advance, All work will be done under his supervision and direction, including approval of material.
6. Contractor is responsible for the regulations of traffic, road signs with proper marking and, if applicable, proper lighting at night, etc.
7. Backfill procedure outlined in M.T.C. Standard DD-813-A, should be applied to all culverts crossing County Roads (frost tapers - when necessary).

**ENGINEER'S REPORT  
WESTERVELT MUNICIPAL DRAIN**

**CONSTRUCTION SATISFACTION STATEMENT**

After completion of the drainage work the Contractor is to supply the Engineer with a signed statement from all property owners whose property abuts the drainage works, signifying the owner's satisfaction with work done by the Contractor.

Should any owner refuse to sign the statement or if the owner is in absentia, the Contractor shall inform the Engineer in writing of the owner's reason, if any, for not signing. Council shall determine if the reasons for refusal are valid.

**STATEMENT**

Name of Owner: \_\_\_\_\_

Property Description: \_\_\_\_\_

**To the property owner:**

Please indicate if you are satisfied or not satisfied with the drainage construction work performed on your property. If you are not satisfied with the work, please provide reasons if applicable.

I am satisfied with the work performed \_\_\_\_\_

I am not satisfied with the work performed \_\_\_\_\_

Reasons (if applicable) \_\_\_\_\_

\_\_\_\_\_

\_\_\_\_\_  
Signature of property owner

\_\_\_\_\_  
Date



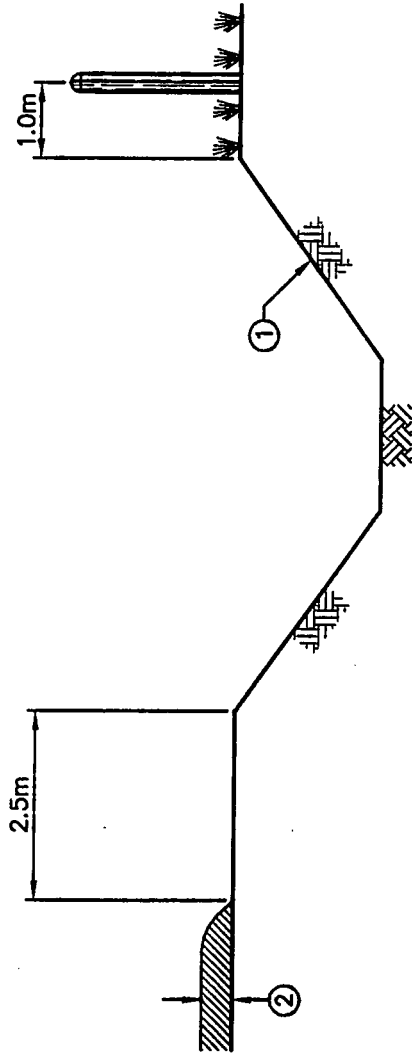

**TYPICAL EARTH CUT SECTION**

**NOTES:**

- ① DITCH SIDE SLOPES TO BE 2 HORIZONTAL TO 1 VERTICAL UNLESS OTHERWISE SPECIFIED.
- ② EARTH SPOIL SPREADING DEPTH NOT TO EXCEED 15cm ON AGRICULTURAL LAND & 30cm ON WOODLOT.
- ③ PIPE DIAMETER TO BE INSTALLED 10cm BELOW DITCH PROPOSED GRADE, UNLESS OTHERWISE SPECIFIED.
- ④ MINIMUM DEPTH OF COVER TO BE 300mm OR C.S.P. DIAMETER DIVIDED BY 6 WHICHEVER IS GREATER. COVER NOT TO BE BELOW FIELD LEVEL.
- ⑤ RIP-RAP TO BE INSTALLED AT 1/2 HORIZONTAL TO 1 VERTICAL SIDE SLOPE.

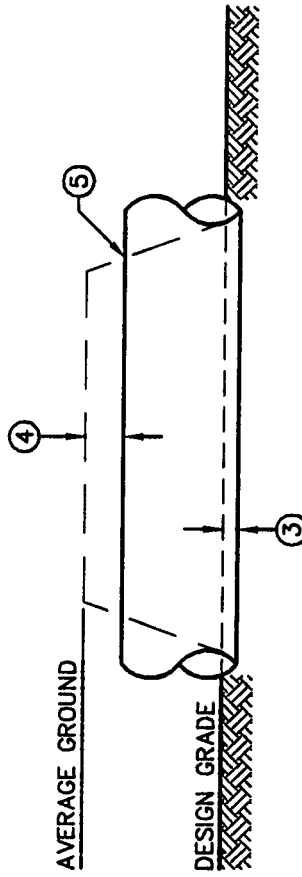

**FARM CULVERT INSTALLATION**



**totten sims hubicki associates**  
ENGINEERS ARCHITECTS AND PLANNERS

DATE: FEB. 1997

PROJECT: 18-12489

SCALE: N.T.S.

**MUNICIPAL DRAIN  
STANDARD DRAWING**

**DWG No. 1**



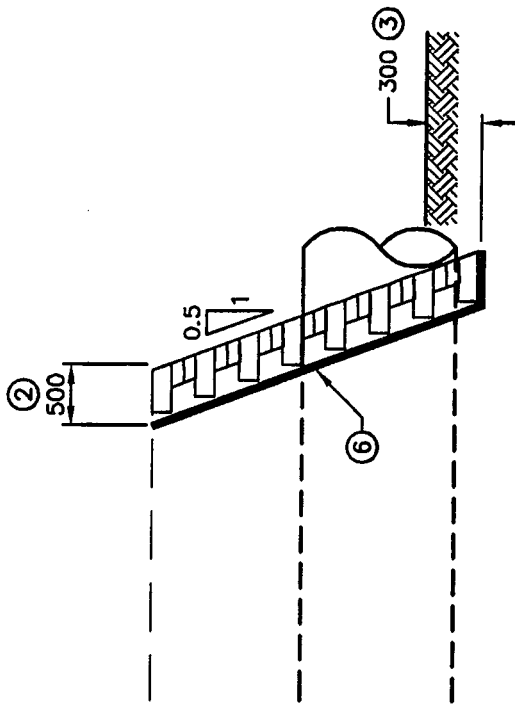

**RIP-RAP INSTALLATION  
AT FARM CROSSINGS**

**NOTES:**

- ① CULVERT RIP-RAP STONE TO BE FLAT BLASTED QUARRY STONE WITH NO DIMENSION LESS THAN 200mm.
- ② KEY STONES TO HAVE MINIMUM DEPTH OF 0.5 METRES INSTALLED AT 1.0m INTERVALS.
- ③ RIP-RAP TO EXTEND A MINIMUM OF 300mm BELOW DITCH BOTTOM GRADE LINE.
- ④ BACKFILL TO BE COMPACTED IN LAYERS NOT EXCEEDED 300mm.
- ⑤ RIP-RAP TO EXTEND TO WITHIN 300mm OF DITCH BANK UNLESS OTHERWISE SPECIFIED.
- ⑥ GEOTEXTILE FILTER CLOTH AS SPECIFIED.

DATE: FEB. 1997

PROJECT: 18-12489

SCALE:  
N.T.S.

**MUNICIPAL DRAIN  
STANDARD DRAWING**

**DWG No. 2**

**totten sims hubicki associates**  
ENGINEERS ARCHITECTS AND PLANNERS





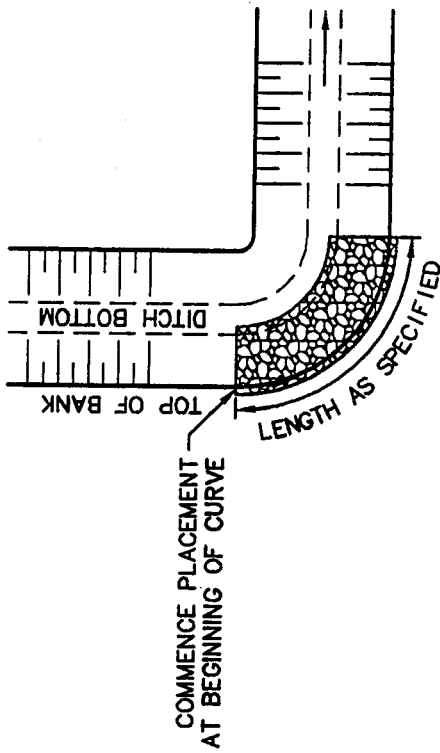

**PLAN**  
**RIP-RAP PROTECTION AT SHARP CORNER BENDS**

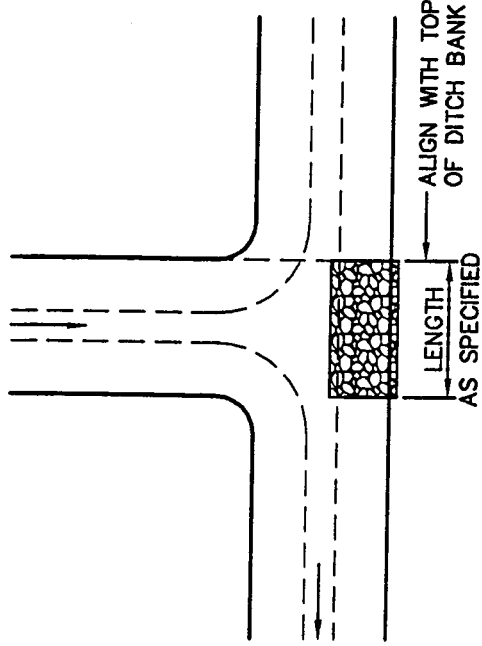

**PLAN**  
**RIP-RAP PROTECTION AT DITCH JUNCTIONS**

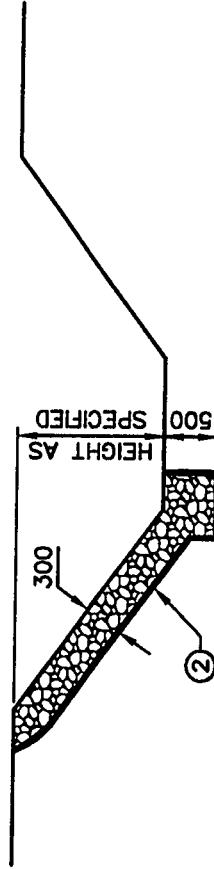

**CROSS-SECTION**  
**RIP-RAP PROTECTION AT SHARP CORNER BENDS**

**NOTES:**

- ① MINIMUM RIP-RAP DIMENSION TO BE 150mm.
- ② GEOTEXTILE FILTER FABRIC AS SPECIFIED.
- ③ THE LARGEST STONES ARE TO BE PLACED BELOW THE TOE OF THE DITCH BANK.
- ④ MINIMUM THICKNESS TO BE 300mm.
- ⑤ HEIGHT AND LENGTHS AS SPECIFIED.

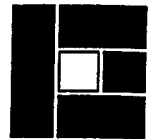

**totten sims hubicki associates**  
 ENGINEERS ARCHITECTS AND PLANNERS

DATE: FEB. 1997

PROJECT: 18-12489

SCALE: N.T.S.

**MUNICIPAL DRAIN**  
**STANDARD DRAWING**

**DWG No. 3**



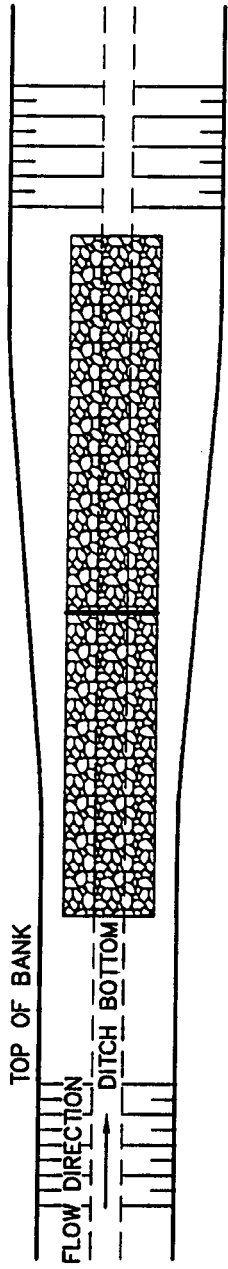

**PLAN**  
GABION DROP STRUCTURE

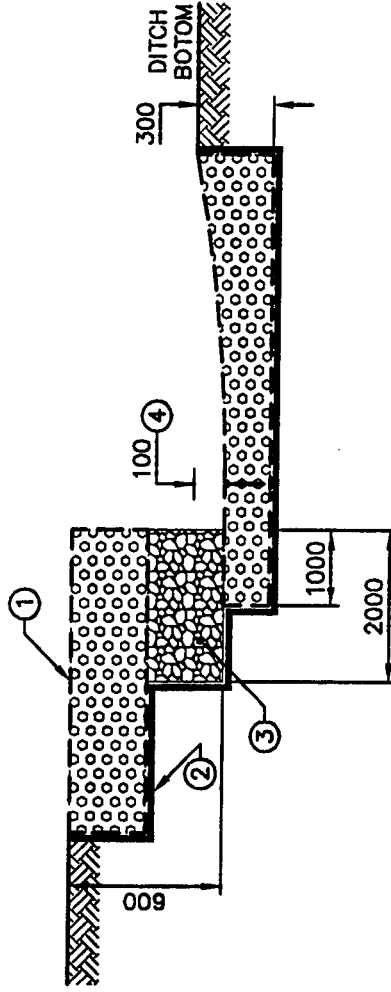

**PROFILE**  
GABION DROP STRUCTURE

**NOTES:**

- ① WIRE BASKET GABIONS; DIMENSIONS AS SPECIFIED.
- ② GEOTEXTILE FILTER FABRIC AS SPECIFIED.
- ③ RIP-RAP BETWEEN GABION BASKET OVERLAP.
- ④ DROP STRUCTURE APEX TO BE 100mm BELOW DITCH GRADE.
- ⑤ LOWER THAN DITCH BOTTOM GRADE.

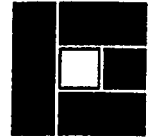

**totten sims hubicki associates**  
ENGINEERS ARCHITECTS AND PLANNERS

DATE: FEB. 1997

PROJECT: 18-12489

SCALE: N.T.S.

**MUNICIPAL DRAIN  
STANDARD DRAWING**

**DWG No. 4**

